



String Trimmer

Owner/Operator Manual

Model

946150 – ST622 CARB



GB ENGLISH

01284000 11/07
Printed in USA

TABLE OF CONTENTS

Safety	5
Assembly	9
Controls and Features	10
Operation	11
Maintenance	13
Service and Adjustments	14

Troubleshooting	18
Storage	19
Service Parts	19
Specifications	19
Warranty	20

INTRODUCTION

NON-ENGLISH MANUALS

Manuals in languages other than English may be obtained from your Dealer. Visit your dealer or www.ariens.com for a list of languages available for your equipment.

Manuals printed in languages other than English are also available as a free download on our website:

<http://www.ariens.com>

MANUALES EN IDIOMAS DIFERENTES DEL INGLES

Puede obtener manuales en idiomas diferentes del inglés en su distribuidor. Visite a su distribuidor o vaya a www.ariens.com para obtener una lista de idiomas disponibles para su equipo.

También puede imprimir manuales en idiomas diferentes del inglés descargándolos gratuitamente de nuestra página Web:

<http://www.ariens.com>

MANUELS NON ANGLAIS

Des manuels dans différentes langues sont disponibles chez votre revendeur. Rendez-vous chez votre revendeur ou allez sur le site www.ariens.com pour consulter la liste des langues disponibles pour votre équipement.

Les manuels imprimés dans des langues différentes de l'anglais sont également disponibles en téléchargement gratuit sur notre site Web :

<http://www.ariens.com>

THE MANUAL

Before operation of unit, carefully and completely read your manuals. The contents will provide you with an understanding of safety instructions and controls during normal operation and maintenance.

All reference to left, right, front, or rear are given from operator standing in operation position and facing the direction of forward travel.

MODEL AND SERIAL NUMBERS

When ordering replacement parts or making service inquiries, know the Model and Serial numbers of your unit and engine.

Numbers are located on the product registration form in the unit literature package. They are printed on a serial number label, located on the frame of your unit.

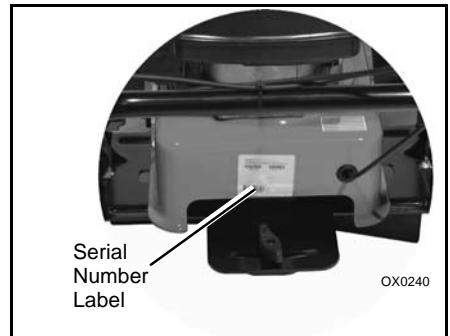

- Record Unit Model and Serial numbers here.

- Record Engine Model and Serial numbers here.

PRODUCT REGISTRATION

The Ariens dealer must register the product at the time of purchase. Registering the product will help the company process warranty claims or contact you with the latest service information. All claims meeting requirements during the limited warranty period will be honored, whether or not the product registration card is returned. Keep a proof of purchase if you do not register your unit.

Customer Note: If the Dealer does not register your product, please fill out, sign and return the product registration card to Ariens or go to www.ariens.com on the internet.

UNAUTHORIZED REPLACEMENT PARTS

Use only Ariens replacement parts. Replacing any part on this vehicle with anything other than an Ariens authorized replacement part may adversely affect the performance, durability, or safety of this unit and may void the warranty. Ariens disclaims liability for any claims or damages, whether warranty, property damage, personal injury or death arising out of the use of unauthorized replacement parts. To locate your nearest Ariens Dealer, go to www.ariens.com on the internet.

DELIVERY

Customer Note: If you have purchased this product without complete assembly and instruction by your retailer, it is your responsibility to:

- Read and understand all assembly instructions in this manual. If you do not understand or have difficulty following the instructions, contact your nearest Ariens Dealer for assistance. To locate your nearest Ariens Dealer, go to www.ariens.com on the internet.



WARNING: Improper assembly or adjustments can cause serious injury.

- Do not operate the unit unless all controls function as described in this manual.

Before attempting to operate your unit:

1. Make sure all assembly has been properly completed.
2. Understand all Safety Precautions provided in the manuals.
3. Review control functions and operation of the unit.
4. Review recommended lubrications, maintenance and adjustments.
5. Review Limited Warranty Policy.
6. Fill out Original Purchaser Registration Card and return the card to Ariens Company or go to www.ariens.com.

DISCLAIMER

Ariens reserves the right to discontinue, change, and improve its products at any time without notice or obligation to the purchaser.

The descriptions and specifications contained in this manual were in effect at printing. Equipment described within this manual may be optional. Some illustrations may not be applicable to your unit.

SAFETY

SAFETY ALERTS



Look for these symbols to point out important safety precautions. They mean:



Attention!

Personal Safety Is Involved!

Become Alert!

Obey The Message!

The safety alert symbols above and signal words below are used on decals and in this manual.

Read and understand all safety messages.



DANGER: IMMINENTLY HAZARDOUS SITUATION! If not avoided, WILL RESULT in death or serious injury.



WARNING: POTENTIALLY HAZARDOUS SITUATION! If not avoided, COULD RESULT in death or serious injury.



CAUTION: POTENTIALLY HAZARDOUS SITUATION! If not avoided, MAY RESULT in minor or moderate injury. It may also be used to alert against unsafe practices.

NOTATIONS

NOTE: General reference information for proper operation and maintenance practices.

IMPORTANT: Specific procedures or information required to prevent damage to unit or attachment.

PRACTICES AND LAWS

Practice usual and customary safe working precautions, for the benefit of yourself and others. Understand and follow all safety messages. Be alert to unsafe conditions and the possibility of minor, moderate, or serious injury or death. Learn applicable rules and laws in your area.

REQUIRED OPERATOR TRAINING

If unit is to be used by someone other than original purchaser; loaned, rented or sold, ALWAYS provide this manual and any needed safety training before operation.

SAFETY DECALS AND LOCATIONS

ALWAYS replace missing or damaged Safety Decals. Refer to figure below for Safety Decal locations.

1. DANGER! TO AVOID SERIOUS INJURY OR DEATH



OL1801

Read the Operator's Manual.



OL4740

Always wear protective glasses, goggles or a face shield.

Always wear adequate hearing protection.



OL4370

Do not operate when children or others are around.



OL0910

Remove objects that could be thrown by the cutter line.



OL4620

Keep body parts away from rotating cutter line.



OL4610

Go across slopes, not up and down.

⚠ DANGER / PELIGRO

NO AVOID SERIOUS INJURY OR DEATH

- Read the Operator Manual.
- Always wear protective glasses or goggles.
- Always wear adequate hearing protection.
- Do not operate when children or others are around.
- Remove objects that could be thrown by the cutter line.
- Keep body parts away from rotating cutter line.
- Do not operate up slopes or down slopes.
- Always use proper mowing technique.
- Do not mow over or near ditches, holes, potholes, etc. or over curbs, sidewalks, driveways, etc.
- Do not mow over or near power lines.
- Do not mow over or near structures, buildings, etc.
- Do not mow over or near people.
- Do not mow over or near animals.
- Do not mow over or near water.
- Do not mow over or near trees.
- Do not mow over or near power lines.
- Do not mow over or near structures, buildings, etc.
- Do not mow over or near people.
- Do not mow over or near animals.
- Do not mow over or near water.
- Do not mow over or near trees.

EVITAR LESIONES GRAVES O LA MUERTE

- Lea el Manual del Operador.
- Siempre use gafas protectoras de seguridad.
- Siempre use protección adecuada para los oídos.
- No opere cuando haya niños u otras personas alrededor.
- Quite los objetos que puedan ser lanzados por la línea de corte.
- Mantenga las partes del cuerpo alejadas de la línea de corte giratoria.
- No opere en pendientes ni en terrenos que sean demasiado resbaladizos.
- No opere sobre zanjas, agujeros, pozos, etc. ni sobre bordillos, aceras, veredas, etc. ni sobre aceras, veredas, etc.
- No opere sobre o cerca de líneas eléctricas.
- No opere sobre o cerca de edificios, edificios, etc.
- No opere sobre o cerca de personas.
- No opere sobre o cerca de animales.
- No opere sobre o cerca de agua.
- No opere sobre o cerca de líneas eléctricas.
- No opere sobre o cerca de edificios, edificios, etc.
- No opere sobre o cerca de personas.
- No opere sobre o cerca de animales.
- No opere sobre o cerca de agua.
- No opere sobre o cerca de líneas eléctricas.

1

EVITARE SERIOUS INJURY OR DEATH

- Read the Operator Manual.
- Always wear protective glasses or goggles.
- Always wear adequate hearing protection.
- Do not operate when children or others are around.
- Remove objects that could be thrown by the cutter line.
- Keep body parts away from rotating cutter line.
- Do not operate up slopes or down slopes.
- Always use proper mowing technique.
- Do not mow over or near ditches, holes, potholes, etc. or over curbs, sidewalks, driveways, etc.
- Do not mow over or near power lines.
- Do not mow over or near structures, buildings, etc.
- Do not mow over or near people.
- Do not mow over or near animals.
- Do not mow over or near water.
- Do not mow over or near trees.

Other Line Lengths: 18 inches (45.7 cm)

Compare to Model No. CC-2001 (18.5")

Length of the Line: 46 inches (116.8 cm)



- Keep safety devices (guards, shields, switches, etc.) in place and working.
- Look down and behind before and while moving backwards.
- Do not let debris accumulate. Debris could become a fire hazard or cause engine to overheat.

SAFETY RULES

If unit is to be used by someone other than original purchaser; loaned, rented or sold, ALWAYS provide this manual and any needed safety training before operation.

Read, understand and follow all safety practices in Owner/Operator Manual before beginning assembly. Failure to follow instructions could result in personal injury and/or damage to unit.

ALWAYS disconnect wire from spark plug before assembly. Unintentional engine start up can cause death or serious injury.

Complete a walk around inspection of unit and work area to understand:

- work area
- your unit
- all safety decals.

Clear work area of stones, sticks, wire and foreign objects which might be picked up and thrown. Tall grass can hide obstacles.

Know the work area. Stay alert for holes, rocks, rough terrain and hidden hazards.

Keep away from drop-offs, ditches, or embankments that could cause operator to lose footing or control of unit.

ALWAYS be aware of traffic when operating along streets or curbs.

Keep work area clear of all persons, children and pets.

Keep children out of the work area and under the watchful care of a responsible adult.

ALWAYS operate unit when there is good visibility and light.

Do not operate trimmer in wet grass.

ALWAYS be sure of your footing. Keep a firm hold on handlebar. Walk, NEVER run.

Whenever operator releases control on handlebar, trimmer head must stop. Check this feature frequently. If feature fails to operate, disconnect spark plug wire and adjust or have it repaired before using unit.

Only trained adults may operate unit. Training includes actual operation.

NEVER operate after or during the use of medication, drugs or alcohol. Unit requires complete and unimpaired attention.

NEVER allow children to operate trimmer.

ALWAYS keep hands and feet away from rotating parts. Rotating parts can cut off body parts.

ALWAYS keep hands away from pinch points. Fumes from engine exhaust can cause death or serious injury. DO NOT run engine in an enclosed area.

ALWAYS protect eyes, face, and body with adequate safety gear and protective clothes. Wear sturdy footwear, gloves and safety goggles or safety glasses with side shields while operating mower.

NEVER operate trimmer barefoot or when wearing open sandals or canvas shoes.

NEVER wear loose clothes, long hair or jewelry that may get caught in rotating parts.

Protect eyes, face and head from objects that may be thrown from unit.

ALWAYS stand clear of discharge when operating unit.

NEVER direct discharge toward bystanders.

Operator is responsible for bystander safety.

DO NOT touch hot parts. Allow parts to cool.

Keep safety devices or guards in place and functioning properly. NEVER modify or remove safety devices.

Read, understand, and follow all instructions in the manual and on the machine before starting. Understand:

- How to operate all controls
- The functions of all controls
- How to STOP in an emergency.

DO NOT attempt to start your engine until you know what the controls do and how they work.

DO NOT tilt trimmer when starting it.

Keep feet away when starting engine.

DO NOT operate trimmer unless trimmer shield and trailing shield are installed. Objects may be picked up and thrown causing damage or personal injury.

NEVER use wire or wire-rope in place of the cutting line. It can break off and become a dangerous projectile. Use only flexible, non-metallic line recommended by Ariens.

ALWAYS keep trimmer head in contact with the ground while operating.

Take all possible precautions when leaving unit unattended.

ALWAYS shut off engine and disconnect spark plug wire to prevent accidental starting or unauthorized use.

Stop engine if anyone enters the work area.

NEVER attempt to make any adjustments to unit while engine is running (except where specifically recommended). Stop engine, disconnect spark plug wire and wait for all moving parts to stop before servicing.

DO NOT make cutting height adjustments while the engine is running.

If you strike an object, or if equipment vibrates abnormally, stop engine at once, wait for moving parts to stop and disconnect wire from spark plug. Repair any damage before restarting unit.

ALWAYS shut off engine, allow trimmer head to stop and disconnect spark plug wire before clearing clogs or cleaning unit.

DO NOT transport machine while engine is running.

To reduce fire hazard and overheating, keep equipment free of grass, leaves, debris or excessive lubricants.

Use extra care when approaching blind corners, shrubs, trees, or other objects which may obscure vision.

DO NOT trim at too fast a rate. DO NOT change engine governor setting or over-speed the engine.

Do not operate trimmer on gravel or on loose material such as sand. Stop trimmer when crossing gravel drives, walks, or roads to prevent damage or injury from thrown objects.

DO NOT pull trimmer backwards unless absolutely necessary. Look down and back, especially for small children, before and while moving backwards.

DO NOT operate on steep slopes.

NEVER leave unit unattended on a slope. Chock wheels if parking on a slope.

Trim across the face of slopes, never up and down. Be especially cautious when changing direction on slopes.

This product is equipped with an internal combustion engine. DO NOT use on or near any unimproved, forest or brush covered land unless the exhaust system is equipped with a spark arrestor meeting applicable local, state or federal laws. A spark arrestor, if used, must be maintained in effective working order by the operator. See your Ariens Dealer or engine manufacturer's service center.

Emission Control System Certification Label

NOTE: Tampering with emission controls and components by unauthorized personnel may result in severe fines or penalties. Emission controls and components can only be adjusted by EPA and/or CARB authorized service centers. Contact your Ariens Equipment Retailer concerning emission controls and component questions.

Fuel is highly flammable and its vapors can explode. ONLY use approved fuel containers.

- NO Smoking!
- NO Sparks!
- NO Flames!
- Allow engine to cool before filling fuel tank.

Never fill containers inside a vehicle or on a truck or trailer bed with a plastic liner. Always place containers on the ground away from your vehicle before filling.

When practical, remove gas-powered equipment from the truck or trailer and refuel it on the ground. If this is not possible, then refuel such equipment on a trailer with a portable container, rather than from a gasoline dispenser nozzle.

Keep the nozzle in contact with the rim of the fuel tank or container opening at all times until fueling is complete. Do not use a nozzle lock-open device.

Check fuel supply before starting engine.

DO NOT fill gasoline tank indoors, when engine is running, or while engine is hot.

Allow engine to cool several minutes before removing fuel cap.

DO NOT overfill. Allow about 1/4" (6 mm) of tank space for fuel expansion.

Replace gasoline tank cap securely and clean any spilled fuel before starting engine.

If fuel is spilled on clothing, change clothing immediately.

NEVER store fuel inside where there is an open flame, such as a water heater.

ALWAYS drain fuel outdoors away from ignition sources.

Avoid Electric Shock. DO NOT disconnect wire from spark plug while engine is running.

Accidental engine start up can cause death or serious injury. Except where specifically recommended, ALWAYS stop engine, wait for moving parts to stop, allow parts to cool and disconnect spark plug wire before inspecting, servicing, adjusting or repairing unit.

Keep unit free of grass, leaves, or other debris build-up.

Keep equipment in good condition.

Maintain or replace safety and instruction labels, as necessary.

Follow engine manufacturer's safety instructions when servicing engine.

Check all hardware at regular intervals, especially trimmer head attachment bolts.

Keep all hardware properly tightened.

Before tipping unit, remove fuel.

DO NOT tip the trimmer up or over unless specifically instructed to do so.

Ensure all wheel blocks, jack stands and tie downs will support unit during maintenance.

Replace worn-out mufflers immediately.

Continued use could result in fire or explosion.

Sharp edges can cut or amputate fingers or a hand. Wrap blade or wear sturdy gloves to service.

Use only replacement parts designed for your unit. See your Ariens Dealer.

Allow engine to cool before storing in any enclosure.

ALWAYS clean unit before extended storage. See engine manual for proper storage.

DO NOT store unit inside a building with fuel in the fuel tank where any ignition sources are present.

Use only accessories which have been approved by Ariens and are properly installed.

Check attachments frequently and replace worn or damaged components with manufacturer's recommended parts.

ASSEMBLY



WARNING: AVOID INJURY. Read and understand the entire *Safety* section before proceeding.

TOOLS REQUIRED

- Box knife to cut carton

TO REMOVE UNIT FROM CARTON

1. Cut off top of box.
2. Remove packing material.
3. Remove literature pack, safety glasses and bottle of oil from box.
4. Cut out back of box and pull the unit out.
5. Remove protective packaging materials from trimming head and around unit.

ASSEMBLY

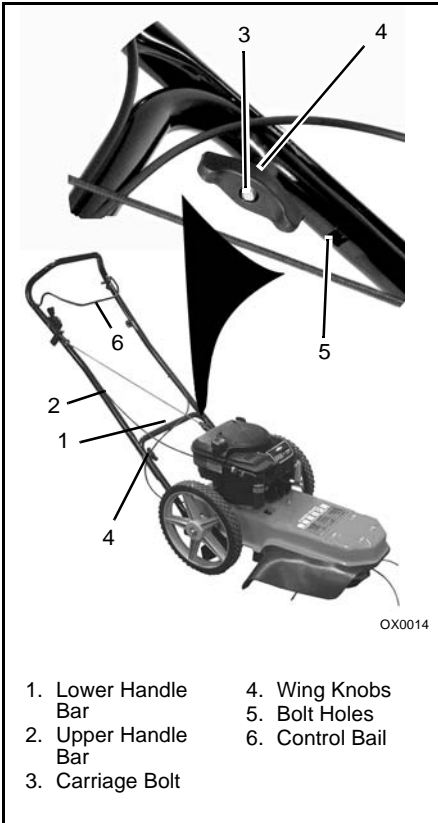

Handlebar Assembly

1. Loosen handlebar wing knobs. Do not remove them.
2. Unfold handlebar to operating position.

NOTE: Adjust handlebar to a height comfortable for the operator. Be sure cable is clear of pinch points. Refer to *Handlebars* in *Service and Adjustments*.

3. Tighten handlebar wing knobs to secure upper handlebar.

Engine Crankcase Oil

Fill engine crankcase with proper amount and viscosity of oil. Refer to Engine Manual for specific information.

CHECKLIST

Please complete the following checklist before proceeding:

- All assembly instructions have been completed.
- No remaining loose parts in carton.
- Handlebar is adjusted comfortably and tightened securely.

While learning how to use your unit, pay extra attention to the following important items:

- Trimming line is fastened securely in holder.
- Fuel tank is filled with proper fuel.
- Engine crankcase is filled with oil.
- Become familiar with all controls – their location and function. Operate them before you start the engine.

CONTROLS AND FEATURES

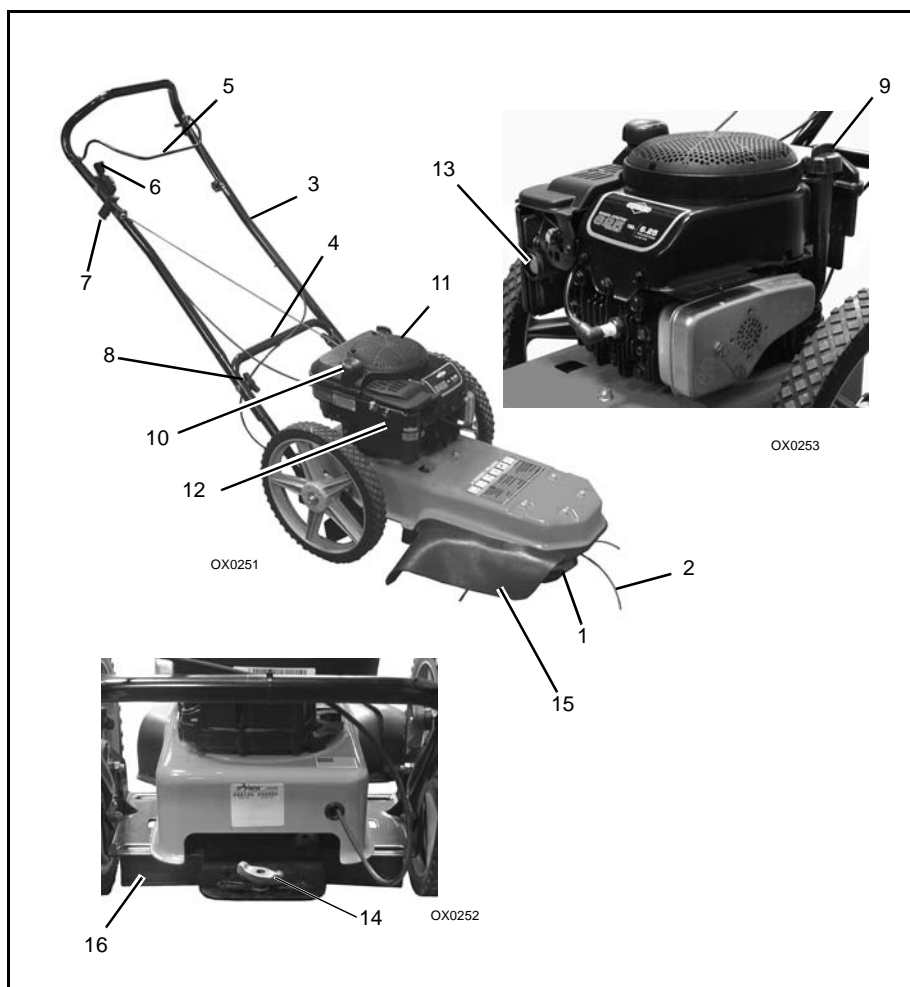

- | | |
|---------------------------|-------------------------|
| 1. Trimmer Head | 9. Oil Dipstick and Cap |
| 2. Trimmer Line | 10. Fuel Tank and Cap |
| 3. Upper Handlebar | 11. Debris Screen |
| 4. Lower Handlebar | 12. Air Cleaner |
| 5. Control Bail | 13. Primer Bulb |
| 6. Throttle Control Lever | 14. Swivel Head Lock |
| 7. Recoil Starter Handle | 15. Trimmer Shield |
| 8. Handlebar Wing Knob | 16. Trailing Shield |

OPERATION

CONTROLS AND FEATURES

See Controls and Features on page 10.



WARNING: AVOID INJURY. Read and understand the entire *Safety* section before proceeding.

Trimmer Head / Trimmer Lines

The trimmer head holds the trimmer line and provides trimming height adjustment. When mounted in the trimmer, the trimmer lines extend about 8 in. (20.3 cm) from the cutter disk.

Control Bail

- Squeeze the trimmer control bail against the handlebar to engage trimmer head.
- Release bail to disengage trimmer.

IMPORTANT: Check control bail function before each use. If control bail moves freely with no resistance before contacting handlebar, adjust or repair unit before operating. See *Service and Adjustments*.

Throttle Control Lever

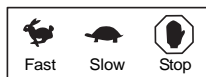

OX0210

The throttle control lever controls the speed of the engine. The settings are variable between fast and slow.

Recoil Starter Handle

The recoil starter handle is used to start the engine.

Primer Bulb



OX0040

For a cold engine, push the primer bulb three times to add fuel for easier engine start. See *Starting and Shut Off*.

Swivel Head Lock

The swivel head feature is designed to allow close trimming while walking parallel to fences or walls.

- Point the front of the unit to the left if trimming with the left side of the trimmer.
- Point the front of the unit to the right if trimming with the right side of the trimmer. To adjust, see *Service and Adjustments*.

FILLING FUEL TANK



WARNING: EXPLOSIVE VAPORS and **FLAMMABLE FUEL** can result in serious injury or death. Handle fuel with care. **ALWAYS** use an approved fuel container. No Smoking! No Lighted Materials! No Open Flame!
Allow engine to cool before maintenance.
Never fill tank when engine is running or is hot from operation. **DO NOT** overfill tank. Allow about 1/4" (6.35 mm) of space at the top of the filler neck for fuel expansion. Wipe up any spills and allow vapors to dissipate before starting engine. Use approved (Red) gasoline container.

To add fuel to Fuel Tank:

1. Put unit in open or well-ventilated area.
2. Stop engine and allow to cool.
3. Clean Fuel Cap and surrounding area to prevent dust, dirt and debris from entering Fuel Tank.
4. Remove Cap.

IMPORTANT: DO NOT use gasohol or gasoline containing alcohol because alcohol will cause internal parts to deteriorate. See Engine Manual for correct type and grade of fuel.

5. Fill fuel tank. (See *Specifications* for tank capacity.)
6. Replace Fuel Cap and tighten.
7. **ALWAYS** clean up any spilled fuel.

TO STOP IN AN EMERGENCY

To stop in an emergency, release control bail. When all moving parts have stopped, push throttle control lever to stop.

TO START AND SHUT OFF ENGINE

Pre-Start

1. Check engine oil level. See Engine Manual.
2. Check fuel level.

Starting the Engine

1. Push primer bulb 2 or 3 times for a cold engine.
2. Set throttle control to Fast.
3. Grasp starter handle and pull rope out slowly until it pulls harder. This is the compression stroke. Let rope rewind slowly. Then pull rope with rapid continuous full arm stroke to start engine. Allow rope to rewind slowly.

IMPORTANT: DO NOT let starter handle snap against handlebar.

4. Repeat until engine starts. (If engine does not start, refer to *Troubleshooting*.)

Stopping the Engine

1. Release control bail so that trimmer head stops rotation. Wait until rotating parts stop completely before leaving operator's position.
2. Push throttle control lever to Stop.
3. If leaving unit unattended, disconnect spark plug wire to prevent start-up.

TO OPERATE THE TRIMMER



CAUTION: Before every use, clean grass and debris from foam debris screen and around muffler.

1. Start the engine.
2. Set throttle control to Fast.
3. Hold the control bail against the handlebar to engage the trimmer head.
4. When trimmer head is rotating at full speed, move unit forward to trim.

TO TRAVEL TO ANOTHER WORK AREA

When crossing driveways or bare areas, release the control bail to stop trimmer head rotation and push down slightly on the handlebar to lift the trimmer head off the ground. This prevents premature wear of the trimmer head.

TRIMMING TIPS

- Operating the trimmer in Fast throttle provides the best trimming performance.
- In heavy growth, walk slower.
- Do not push the trimmer into heavy growth too fast.
- Do not trim on extremely steep slopes. Do not trim on slopes when the ground is wet or slippery. If you do not feel comfortable on a slope, do not trim it.
- Keep the trimmer clear of dirt and grass build-up.
- Install a new trimmer line when line is worn to less than 4 inches (10.2 cm). See *Service and Adjustments*.

TO TRANSPORT UNIT

ALWAYS turn engine off when transporting on truck or trailer. Tie unit down securely. Do not tie down by linkages, guards, cables or other parts that may be damaged.

MAINTENANCE



WARNING: AVOID INJURY. Read and understand the entire *Safety* section before proceeding.

Maintenance Schedule

Service Performed	Intervals (Hours)		
	Each Use	25	50
Check Fasteners	•		
Check Trimmer Lines	•		
Check Control Bail Operation	•		
Check Engine Oil	•		
Clean Debris Screen	•		
Clean Unit	•1		
Check Air Cleaner		•1	
Check Spark Plug			•
Change Engine Oil	•2	•1	
Clean Engine Cooling Fins		•1	

1. More often under extremely dusty or dirty conditions.
2. Change engine oil after first 2 hours of use, then every 25 hours or every season, whichever comes first.

SERVICE POSITION

1. Remove the gas cap and place a piece of plastic (a plastic garbage bag works well) over the tank opening. Reinstall the cap. This keeps gasoline from spilling out the tank.
2. Set the unit swivel in the center position.
3. Loosen the two wing nuts on the lower handlebar.
4. Tip the unit up onto its back to rest on the lower handlebar. A 4" x 4" (10.2 x 10.2 cm) wood block under the swivel bracket helps steady the unit by tilting it farther back.
5. When service is complete, place unit in its normal operating position.
6. Align handlebars and tighten wing nuts.
7. Be sure to remove the plastic from the gas tank opening.

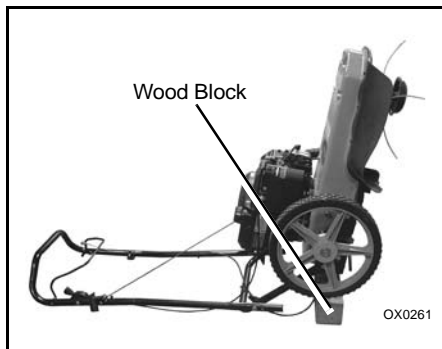

CHECK FASTENERS

Make sure all hardware is tightened properly. Pay special attention to handlebar, guards, shields, and trimmer head mounting hardware.

CHECK TRIMMER LINES

Make sure trimmer line is securely fastened in holder. Replace trimmer line when it is worn to less than 4 inches (10.2 cm). See *Service and Adjustments* for specific instructions.

CHECK CONTROL BAIL OPERATION

The trimmer head must disengage completely when the bail handle is released. Adjust bail travel if necessary. See *Adjustments*.

CHECK ENGINE OIL

See Engine Manual for specific information on checking engine oil.

CLEAN DEBRIS SCREEN

Remove all grass and debris from debris screen on top of engine. A clogged screen will cause the engine to overheat.

CLEAN UNIT

Clean unit thoroughly. Brush dirt and debris off with a brush or cloth. Apply paint or spray lubricant to exposed metal surfaces. Do not use abrasives, solvents, or harsh cleaners.

IMPORTANT: NEVER spray unit with water or store unit outdoors. Store trimmer in a cool, dry, protected location.

CHECK AIR CLEANER

See Engine Manual for specific information on checking and servicing the air cleaner.

CHECK SPARK PLUG

See Engine Manual for specific information on checking, cleaning, and changing the spark plug.

CHANGE ENGINE OIL

Change the engine oil after the first 2 hours of use, then every 25 hours or every season, whichever comes first. Oil should be changed when engine is warm.

1. Disconnect spark plug wire.
2. Clean area around oil cap.
3. Tip the string trimmer on its right side.



CAUTION: Before tipping unit, remove enough fuel so no spillage will occur. A piece of plastic bag may be used to seal fuel tank when tipping unit. To seal, remove fuel tank cap, cover fuel tank opening with plastic, replace and tighten cap securely before attempting to tip unit. Be sure to remove plastic before operating unit.

4. Place a container for the oil under the oil cap.
5. Remove oil cap and let the oil drain. Tip the unit more to drain all the oil from the engine if necessary.
6. Place the unit upright.
7. Refill the engine with oil recommended in the Engine Manual.
8. Replace and tighten oil cap.
9. Clean up any spilled oil.
10. Reconnect the spark plug wire.

CLEAN ENGINE COOLING FINS

Remove grass, dirt and debris from engine cooling fins every 25 hours to prevent damage caused by overheating.

SERVICE AND ADJUSTMENTS



WARNING: AVOID INJURY. Read and understand the entire *Safety* section before proceeding.

REPLACING TRIMMER LINE

Replace the trimmer line when it extends less than 4 inches (10.2 cm) from cutter disk. For best results, use only genuine Ariens replacement trimmer line.

1. Stop the engine and wait for all moving parts to stop. Disconnect the spark plug wire and place it securely away from the spark plug.
2. Remove the worn trimmer line from the cutter disk.
3. Thread the two ends of the trimmer line up from the bottom, through the two holes in the cutter disk.
4. Cross the line and thread the ends of the line through the two holes on the side of the cutter disk.

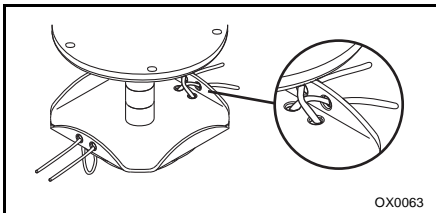

5. Make sure the ends of the line extend through the cutter disk at the same length. Uneven trimmer lines cause the trimmer head to be out of balance, which results in excessive vibration.
6. Pull trimmer line tight.
7. If necessary, cut the ends of the trimmer line to the same length.

HANDLEBAR HEIGHT ADJUSTMENT

1. Loosen and remove both wing knobs from handlebar.
2. Remove carriage bolts, taking care to support handlebar.
3. Set handlebar to desired height.
4. Line up holes in upper handlebar with holes in lower handlebar. Be sure to use the same holes on each side.
5. Reinstall carriage bolts and wing knobs. Tighten securely.

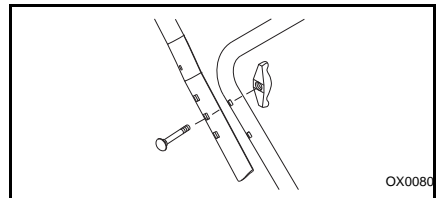

CUTTING HEIGHT ADJUSTMENT

The standard cutting height is adjustable from 1-3/16" to 4-3/8" (3 to 11.1 cm). To raise the cutting height, place more spacers (up to 4) below the cutter disk. Spacers not used under the cutter disk must be assembled above the cutter disk. For example, if you place two spacers under the cutter disk, the other two spacers must be in place above the cutter disk.

NOTE: There must always be at least one spacer between the cutter disk and the height guide.

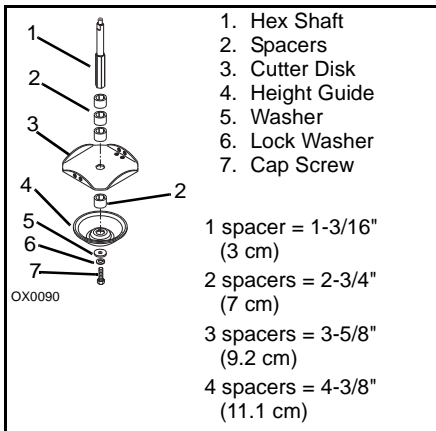

1. Raise the cutter head off the ground.
2. Loosen and remove capscrew, lock washer and washer.
3. Remove height guide and bottom spacer.
4. Remove cutter disk and any of the remaining spacers required to achieve the desired cutting height.
5. Reinstall the cutter disk.
6. Reinstall the spacers required to achieve the desired cutting height.
7. Reinstall height guide on the hex shaft.

NOTE: Be sure the hex shaft and the hex hole in the height guide are correctly aligned.

8. Reinstall washer, lock washer and capscrew. Tighten securely.

NOTE: The minimum cutting height may be lowered to 1-3/16" (3 cm) by using one spacer below the cutter disk and installing the cutter disk upside down on the hex shaft.

HEIGHT GUIDE REPLACEMENT

The height guide requires periodic replacement. When used on hard surfaces, such as concrete, it may need to be replaced more frequently. If height guide is damaged or worn, it must be replaced.

1. Raise the cutter head off the ground.
2. Loosen and remove capscrew, lock washer and washer.
3. Remove worn height guide.
4. Install new height guide.
5. Reinstall hardware and tighten securely.

SWIVEL HEAD ADJUSTMENT

1. Stop the engine and wait for all moving parts to stop. Disconnect the spark plug wire and place it securely away from the spark plug.
2. Loosen the wing knob on the bracket at the rear of the unit.

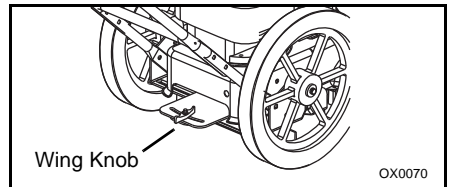

3. Rotate the back of the unit in the opposite direction of the side you wish to cut with.
4. Tighten wing knob securely.

CONTROL BAIL TRAVEL ADJUSTMENT

Control Bail must disengage trimmer head as control is released. There should be a slight amount of slack in the control cable wire when bail is fully released. If the trimmer head does not disengage completely when the control bail is released, increase the amount of slack in the control cable wire as follows:

1. Loosen the bottom cable nut.
2. Push the cable conduit upward toward the control bail.
3. Tighten the upper cable nut onto the mounting bracket to lock the conduit in place.
4. Turn nuts against mount to lock in position.

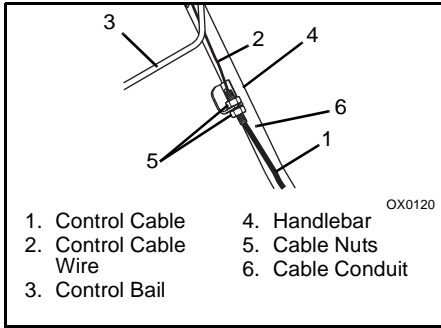

- | | |
|-----------------------|------------------|
| 1. Control Cable | 4. Handlebar |
| 2. Control Cable Wire | 5. Cable Nuts |
| 3. Control Bail | 6. Cable Conduit |

DRIVE BELT REPLACEMENT

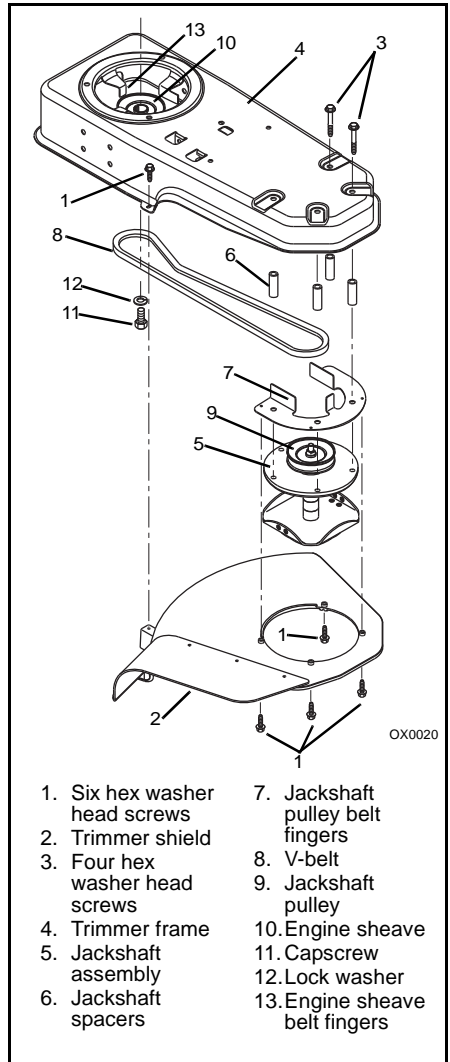

- | | |
|--------------------------------|----------------------------------|
| 1. Six hex washer head screws | 7. Jackshaft pulley belt fingers |
| 2. Trimmer shield | 8. V-belt |
| 3. Four hex washer head screws | 9. Jackshaft pulley |
| 4. Trimmer frame | 10. Engine sheave |
| 5. Jackshaft assembly | 11. Capscrew |
| 6. Jackshaft spacers | 12. Lock washer |
| | 13. Engine sheave belt fingers |

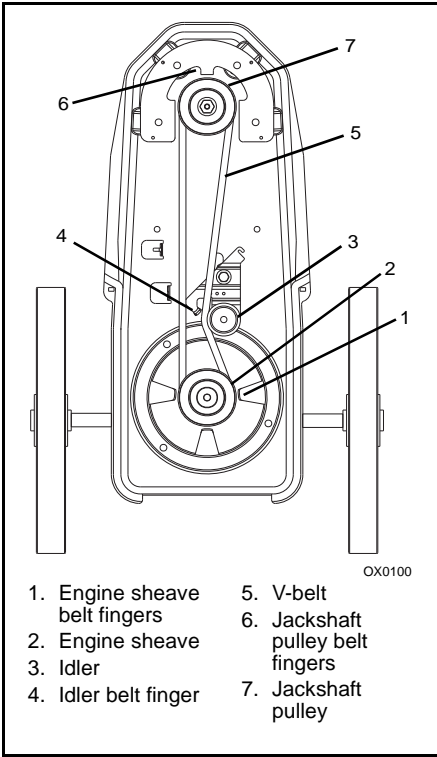

To remove the old belt:

1. Stop the engine and wait for all moving parts to stop. Disconnect the spark plug wire and place it securely away from the spark plug.
2. Place unit in service position (see *Maintenance* section).



CAUTION: Before tipping unit, remove enough fuel so no spillage will occur. A piece of plastic bag may be used to seal fuel tank when tipping unit. To seal, remove fuel tank cap, cover fuel tank opening with plastic, replace and tighten cap securely before attempting to tip unit. Be sure to remove plastic before operating unit.

3. Remove the six (6) hex washer head screws and the trimmer shield.
4. Remove the four (4) hex washer head screws on the top side of the frame. The jackshaft assembly, belt fingers and jackshaft spacers will now be loose.
5. Remove the v-belt from the jackshaft pulley.
6. Remove the capscrew and lock washer from the engine sheave.
7. Lower the engine sheave past the belt fingers and remove the belt.

To install the new belt:

1. Slide the new belt over the groove in the engine sheave and slide the sheave against the engine. Make sure the belt is in the groove and is inside the belt fingers.
2. Install the capscrew and lock washer. Tighten securely.
3. Slide the belt between the idler and belt finger on the idler bracket.
4. Install the four tapping screws in the holes in the frame, from the top side of the frame.
5. Install the four jackshaft spacers on the tapping screws.
6. Install the belt finger. Make sure the bent tabs are facing up and are to the sides and front of the unit.
7. Install the belt in the groove of the jackshaft pulley.
8. Attach the jackshaft assembly to the frame with the four tapping screws. Fasten securely.
9. Reinstall the trimmer shield with the six tapping screws.

TROUBLESHOOTING

PROBLEM	PROBABLE CAUSE	CORRECTION
Engine will not start or runs poorly	<ol style="list-style-type: none"> 1. Spark plug wire disconnected. 2. Engine not primed 3. Fuel tank empty. 4. Throttle control lever not in correct position. 5. Engine is flooded. 6. Defective or incorrectly gapped spark plug. 7. Stale or contaminated gasoline. 8. Engine cooling system overloaded with debris. 9. Dirty carburetor or fuel line. 10. Dirty air filter or precleaner. 11. Carburetor out of adjustment. 	<ol style="list-style-type: none"> 1. Connect spark plug wire. 2. Prime engine. 3. Add fuel to the fuel tank. 4. See Engine Manual. 5. Wait several minutes before attempting to start. 6. Replace or regap spark plug. 7. Drain fuel tank and refill with fresh gasoline. 8. Clean debris screen and cooling fins. 9. Clean carburetor or fuel line. See Engine Manual. 10. Replace air filter or precleaner. 11. See Engine Manual or contact your dealer.
Engine overheats	<ol style="list-style-type: none"> 1. Engine cooling system overloaded with debris. 2. Carburetor out of adjustment. 	<ol style="list-style-type: none"> 1. Clean engine screen and cooling fins. 2. See Engine Manual or contact your dealer.
Poor trimming performance	<ol style="list-style-type: none"> 1. Engine not set at Fast speed. 	<ol style="list-style-type: none"> 1. Set engine throttle to Fast position.
Trimmer vibrates	<ol style="list-style-type: none"> 1. Cutter line lengths are too uneven. 2. Loose hardware. 	<ol style="list-style-type: none"> 1. Trim or adjust cutter line to equal lengths. Replace if necessary. 2. Check all bolts and nuts, including engine mounting hardware, for tightness.

STORAGE



WARNING: AVOID INJURY. Read and understand the entire *Safety* section before proceeding.

If the trimmer is to be stored for more than 30 days, follow these steps to prepare your unit.

1. Run the engine until it stops from running out of gasoline. See Engine Manual for specific instructions on preparing the engine for storage.
2. Clean all dirt and debris from the trimmer. Refer to *Maintenance* for cleaning instructions.
3. Inspect unit for signs of wear, breakage or damage. Order any parts required and make necessary repairs to avoid delays when beginning use again.
4. Keep all nuts, bolts and screws properly tightened and know unit is in safe working condition.

SERVICE PARTS

Be sure to always use genuine Ariens parts to keep your String Trimmer running like new.

Part no.	Qty	Description
07236900	1	Drive Belt
04641800	1	Trimmer Line (Pkg of 6)
04641100	1	Height Guide
04645000	1	Long Life Height Guide

SPECIFICATIONS

Model Number	946150
Description	ST622 CARB
Engine	Briggs & Stratton Quantum
Engine Power - HP (KW)	6.25 (4.66)
Engine Operating Fast Idle Speed - Max. RPM	3750
Engine Displacement - cu. in. (cc)	11.78 (193)
Fuel	See Engine Manual for type and grade
Fuel Tank Capacity - qt (Liters)	1.69 (1.6)
Cutting Width - in (cm)	22 (55.88)
Handlebars Max. Extended Height - in (cm)	41.38 (105.11)
Minimum Folded Height - in (cm)	19.38 (49.23)
Length - in (cm)	57.88 (147.02)
Minimum Folded Length - in (cm)	37.25 (94.62)
Width - in (cm)	22 (55.88)
Weight - lbs (Kg)	83 (37.65)
Cutter Head Speed - Max. RPM	3650
Drive Belt	4L Section, Single "V" Construction, Raw Edge Kevlar Cord
Wheel Size - in (cm)	14 (35.56)
Replacement Line Length - in. (cm)	18 (46)
Diameter - in. (cm)	5/32 (0.40)



Ariens Limited Warranties



2-Year Limited Lawn and Garden Consumer Warranty

Ariens Company (Ariens) warrants to the **original purchaser** that Ariens and Gravely brand consumer products manufactured by Ariens Company will be free from defects in material and workmanship for a period of two (2) years after the date of purchase, and that Ariens will repair any defect in material or workmanship, and repair or replace any defective part, subject to the conditions, limitations and exclusions set forth herein. Such repair or replacement will be free of charge to the **original purchaser** (labor and parts), except as noted below.

The two-year duration of this warranty applies only if the product is put to ordinary, reasonable, and usual personal, family, or household uses. If the product is put to any business, commercial, or industrial use such as, but not limited to, commercial landscaping, mowing or snow removal services, or golf course or park maintenance, or agricultural or farmstead use, then the duration of this warranty is ninety (90) days after the date of purchase, or one (1) year after the date of purchase if the product is labeled as a Professional/Commercial Product. The duration of this warranty shall be ninety (90) days after the date of purchase if any product is rented or leased.

2-Year Limited Lawn and Garden Commercial Warranty

The Ariens Company (Ariens) warrants to the **original purchaser** that all Gravely Pro and ProMaster products manufactured by Ariens will be free from defects in material and workmanship for a period of two (2) years after the date of purchase or 1000 hours of use, whichever comes first. An authorized Gravely dealer will repair any defect in material or workmanship, and repair or replace any defective part, subject to the conditions, limitations and exclusions set forth herein. Such repair or replacement will be free of charge to the **original purchaser** (labor and parts), except as noted below.

The duration of this warranty shall be ninety (90) days after the date of purchase or 1000 hours of use, whichever comes first, if any product is rented or leased.

3-Year Limited Sno-Thro Warranty

Ariens Company (Ariens) warrants to the **original purchaser** that Sno-Thro products manufactured by Ariens Company will be free from defects in material and workmanship for a period of three (3) years after the date of purchase, and will repair any defect in material or workmanship, and repair or replace any defective part, subject to the conditions, limitations and exclusions set forth herein. Such repair or replacement will be free of charge to the **original purchaser** (labor and parts), except as noted below.

The three-year duration of this warranty applies only if the product is put to ordinary, reasonable, and usual personal, family, or household uses. If the product is put to any business, commercial, or industrial use, then the duration of this warranty is ninety (90) days after the date of purchase, or one (1) year after the date of purchase if the product is labeled as a Professional/Commercial Product. The duration of this warranty shall be ninety (90) days after the date of purchase if any product is rented or leased.

DURA-CLEAN™ Auger Limited Lifetime Warranty

Ariens Company (Ariens) warrants to the **original purchaser** that the rubber components of the DURA-CLEAN™ Auger manufactured by Ariens Company will be free from defects in material and workmanship and will not wear out for the life of the Sno-Thro, except as noted below.

Ariens Company will provide for the replacement of any of the rubber components of the DURA-CLEAN™ Auger found upon examination by the Ariens Company to be defective or worn out. Replacements will be supplied free of charge. Labor is not included after two (2) years from the date of purchase of the Sno-Thro.

The lifetime limited warranty shall apply if the product is put to ordinary, reasonable, and usual personal household use. If the product is put to any business, commercial, industrial, rental, or leased use, the warranty shall be against defects in material and workmanship for ninety (90) days following the date of purchase.

Exceptions, Limitations, Exclusions

These warranties are subject to the following conditions, limitations, and exclusions:

To obtain warranty service, the following conditions must be met:

- The purchaser must perform the maintenance and minor adjustments explained in the owner's manual.
- The purchaser must promptly notify Ariens Company or an authorized Ariens service representative of the need for warranty service.
- The purchaser must transport the product to and from the place of warranty service.
- Warranty service must be performed by a respective Ariens or Gravely authorized service representative.
- To find an Ariens or Gravely authorized service representative, contact Ariens at:

655 W. Ryan St.
Brillion, WI 54110-1072
(920) 756 - 2141
www.ariens.com
www.gravely.com

This warranty is subject to the following limitations:

- Genuine Ariens or Gravely brand service parts and accessories not purchased with the product covered by this warranty, but which are later purchased and used with that product, are warranted to be free from defects in material and workmanship for a period of ninety (90) days after date of purchase, and Ariens Company will repair or replace any such part or accessory free of charge, except for labor, during that period.
- Batteries are warranted only for a period of twelve (12) months after date of purchase, on a prorated basis. For the first ninety (90) days of the warranty period, a defective battery will be replaced free of charge. If the applicable warranty period is more than 90 days, Ariens Company will cover the prorated cost of any defective battery, for up to twelve (12) months after the date of purchase.

Ariens may from time to time change the design of its products. Nothing contained in this warranty shall be construed as obligating Ariens to incorporate such design changes into previously manufactured products, nor shall such changes be construed as an admission that previous designs were defective.

LIMITATION OF REMEDY AND DAMAGES

Ariens Company's liability under this warranty, and under any implied warranty that may exist, is limited to repair of any defect in workmanship, and repair or replacement of any defective part. Ariens Company shall not be liable for incidental, special, or consequential damages (including lost profits). Some states do not allow the exclusion of incidental or consequential damages, so the above limitation or exclusion may not apply to you.

This warranty gives you specific legal rights, and you may also have other rights which vary from state to state.

The following items are excluded from this warranty:

- Engines and engine accessories are covered only by the engine manufacturer's warranty and are not covered by this warranty.
- Hydro-Gear transmissions and/or Hydro-Gear drive components are covered only by the Hydro-Gear warranty and are not covered by this warranty.
- Parts that are not genuine Ariens or Gravely brand service parts are not covered by this warranty.
- Except as specifically warranted, normal maintenance, services, and normal replacement items, such as spark plugs, oil, oil filters, air filters, mufflers, belts, tires, shoes, runners, scraper blades, shear bolts, mower blades, mower vanes, headlights, light bulbs, knives, etc. are not covered by this warranty except as noted below.
- Mufflers, belts, and tires on consumer lawn and garden products are warranted to the **original purchaser** for two years.
- Friction discs, idlers, cables, and electrical components on Sno-Thros put to usual personal household use are warranted to the **original purchaser** for two years.
- Any defect which is the result of misuse, alteration, improper assembly, improper adjustment, neglect, or accident is not covered by this warranty.

This warranty applies only to products purchased in the United States (including Puerto Rico) and Canada. In all other countries, contact place of purchase for warranty information.

DISCLAIMER OF FURTHER WARRANTY

Ariens Company makes no warranty, express or implied, other than what is expressly made in this warranty. If the law of your state provides that an implied warranty of merchantability, or an implied warranty of fitness for particular purpose, or any other implied warranty, applies to Ariens Company, then any such implied warranty is limited to the duration of this warranty. Some states do not allow limitations on how long an implied warranty lasts, so the above limitation may not apply to you.



Ariens Company
655 West Ryan Street
Brillion, WI 54110-1072
920-756-2141
Fax 920-756-2407
www.ariens.com

 **WARNING** 

The engine exhaust from this product contains chemicals known to the State of California to cause cancer, birth defects or other reproductive harm.